



GENERAL FEATURES

- Rack size **40x40 cm**
- Gross weight: 47 Kg
- Washing cycles / racks/hour : 90"-120"-180"-∞/
40-30-20
- Top and bottom wash/rinse arms
- Wash pump 330W
- Boiler capacity 4 liters
- Tank capacity 12 liters
- Boiler heating element 2,8 kW
- Tank heating elements 2,4 kW
- Water quantity per cycle: 2 liters
- Electronic controls with color code switch
- Extractable control panel
- Useful washing height: 300 mm
- Magnetic door microswitch
- Automatic water filling
- Built-in electric rinse-aid dispenser
- Built-in electric detergent dispenser
- Hot rinse
- Thermostop function
- Air break
- Atmospheric boiler
- Rinse booster pump
- Automatic end-of-day self cleaning water tank
- Washing pump with Soft-Start

FILTRATION

- Plastic wash pump filter, easily removable

BODY

- AISI 304 stainless steel Body
- Partial double skinned body
- Preformed rack guides
- Preformed wash tank
- Double skinned door
- Door handle in s/s
- Wash/rinse arms in s/s, easily removable
- Boiler in s/s AISI 316
- PVC protection rear the bottom front panel

EQUIPMENT AS GLASSWASHER

- 2 glass racks 40x40 cm
- 1 cutlery small basket
- 1 insert for saucers
- 1 inlet hose (length 2 m)
- 1 drain hose (length 2,5 m)

OPTIONAL

- Drain pump
- Cold rinse
- Kit s/s tank filters for pre-filtering of tank water
- 60 Hz version

ACCESSORIES FOR THE WATER TREATMENT

- Internal water softener ("S" version)

ACCESSORIES

- Special racks (Round, diam. cm.40)
- S/S supporting stand h. 545 mm. for basket

INSTALLATION

- Use the screws of the feet and a spirit level to ensure that the machine is levelled

MAIN POWER SUPPLY

- The voltage of main power supply must be compatible with the rated voltage
- The machine must be connected to a suitable earth (ground) system
- Connect the machine power socket to the multi-pole wall switch provided

WATER SUPPLY CONNECTION

- A water softener must be installed if the water is hard
- The water pressure must be between 0.1MPa (1 bar), and, 0.5MPa (5 bar)
- The temperature of the water-supply must be between 10°C to 50°C

TECHNICAL SPECIFICATIONS

- Voltage: **220-240 V ~ 50 Hz**
- Total power : **3,13kW**
- Amperage: **14 A**
- Power cord supply size : **3x1,5 mmq**

AF 40.30E LS PRS

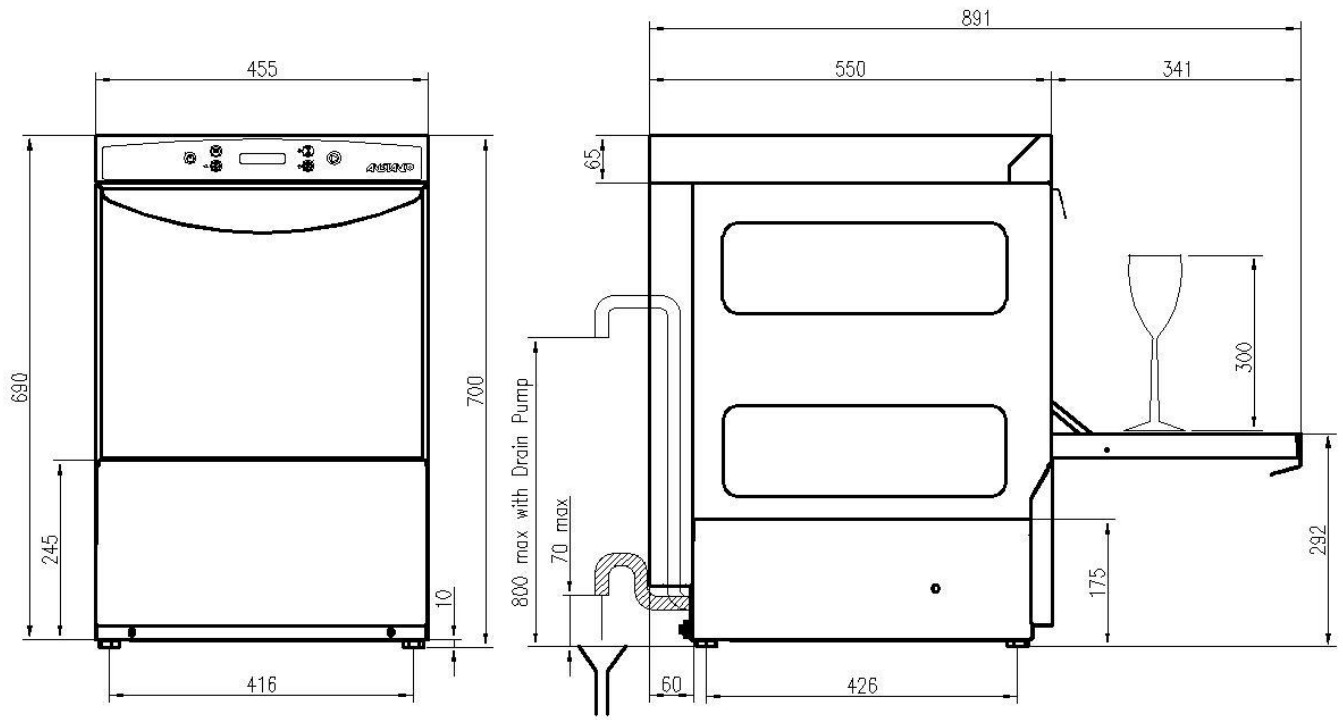

SCARICO
DRAIN
VIDANGE

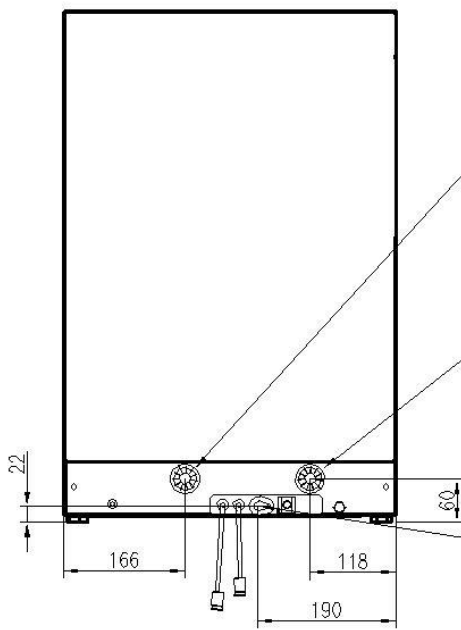

VISTA POSTERIORE
REAR OF MACHINE
VUE ARRIERE

USCITA TUBO DI SCARICO Ø INT. mm.20 L=mm.2500
EXIT WATER OUTLET PIPE INT. Ø 20 mm. L=mm.2500.
OUVERTURE DE PASSAGE TUYAU DE VIDANGE Ø INT. 20 mm. L=mm.2500.

CANNA DI CARICO CON ATTACCO G 3/4" L=mm. 2000.
WATER INLET PIPE CONNECTION G 3/4" L=mm 2000.
OUVERTURE DE PASSAGE TUYAU D'ALIMENTATION EAU AVEC
CONNEXION G 3/4" L=mm 2000.

USCITA CAVO DI ALIMENTAZIONE
EXIT POWER CORD SUPPLY
OUVERTURE DE PASSAGE CABLE D'ALIMENTATION

	Min 10°C-MAX 50°C
	Min 10°C-MAX 25°C with ENERGY RECOVERY
	200÷500kPa(2÷5 Bar)
	100÷500kPa(1÷5 Bar) with ATMOSPHERIC BOILER
	HARDNESS 5÷20°f-2.8÷11°d