



TECHNICAL FEATURES

- Heating of cooking chamber with high performance INCOLOY heating elements.
- Rapid chamber ventilation system.
- Inverter-controlled fan with 6 different speeds.
- Immediate shutdown of the fan rotation by opening the door.
- Steam production by INSTANT mode.
- Super Steam: two different humidity levels
- USB port for uploading and saving recipes and for firmware updating.
- Double-glazed ventilated door (panels can be opened for easy cleaning).
- Cooking chamber lighting with LED.
- AISI 304 cooking chamber with coved corners.
- Height adjustable feet.
- Single control by means of just one jog/dial encoder knob.
- Motorised vent valve opening.

STANDARD EQUIPMENT

- Automatic washing system (Liquid detergent)
- Wi-Fi

OPTIONS:

- Core probe 6000124
- Retractable hand shower
- Left hinged door (or request).

USER INTERFACE:

TOUCH SCREEN PANEL 7"

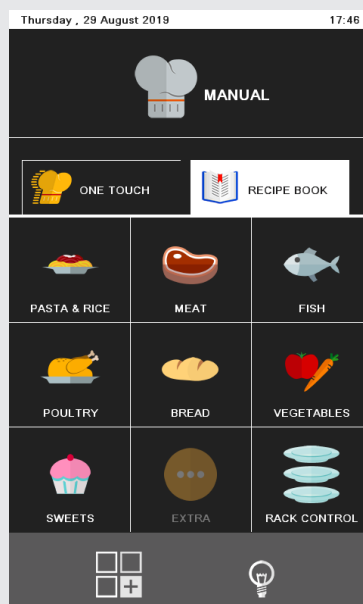

- Temperature control from 50° to 300°C.
- Time control from 1'to120'; infinite function.
- Cooking modes: convection, steam, combi convection/steam.
- Preset cooking programmes. Possibility of controlling 9 cooking phases for each programme.
- "One Touch" cooking mode: immediate start of the cooking cycle with "one touch programs".
- Delta T cooking.
- Cooking with probe.
- Multi level cooking with "Easy service".
- Recipe tuner
- Super Steam.
- Cooldown during cooking.
- Hold function.
- Regeneration function.

OneTouch

To start with a single move the preferred recipes selected and memorized by him with the icon and the name he prefers.

RecipeTuner

The RecipeTuner interface makes it possible to modify and personalise the various programs simply and intuitively. RecipeTuner changes according to the type of cooking set, to regulate cooking, browning, degree of humidity and of leavening.

EasyService

level control cooking

The new Rack Control enables different dishes to be cooked at the same time at various levels. What's more, with EasyService, a new Rack Control function, all the dishes can be served at the same time.

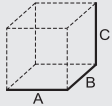
 (A x B x C) cm	VOL./PESO Vol./Weight m ³ /kg	VAC 400V-3N 50/60 Hz kW	POTENZA EL. CAMERA Oven cavity el. power kW	DISTANZA TRA LE TEGLIE Distance between the layers mm	DIM. CAMERA Cavity net dimension mm
112x84,5x111,5 10 GN 2/1	1,34 / 220	25,8	25	70	637x730x750

ACCESSORIES

- Stand TSB12
- Racks for stand TSB12 cod. 2019770
- Neutral cupboards TAN0821
- Stacking kit on demand

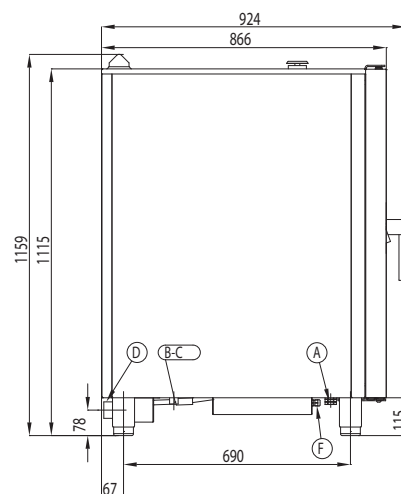
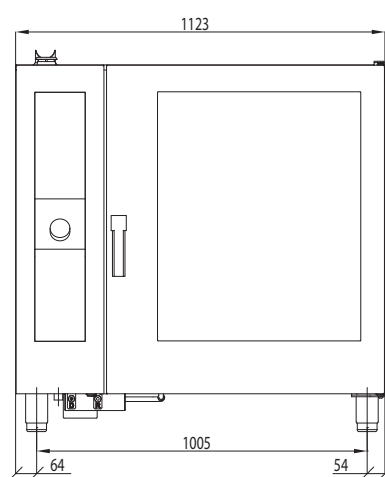

- A Electrical power inlet
- B Softened water inlet (G3/4)
- D Drain connection(Ø50)
- E Cavity Vent (Ø60)
- F Detergent and rinse aid inlet

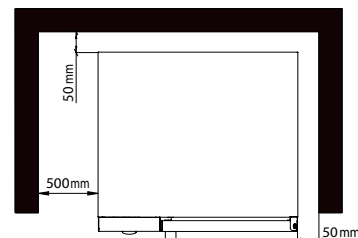
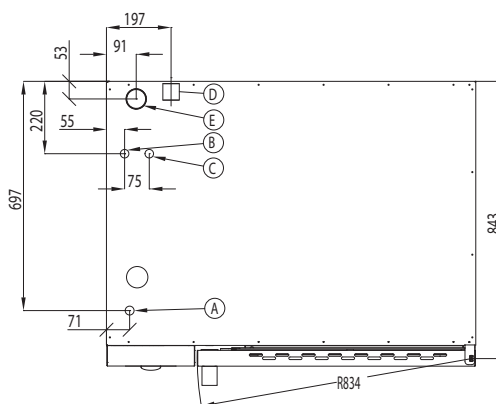

* Clearance requirements

WATER QUALITY REQUIREMENTS

Hardness 60-100 ppm
 TDS <100 mg/L
 PH Value 7.0-8.0
 Cl₂ Free chlorine..... <0,5 mg/L
 Cl Chloride..... <20 mg/L
 Alkalinity..... <20 mg/L
 SiO₂ Silica..... <10 mg/L

NOTE

* Drain line must be vented