

Under Broiler Counter's

Features

- Side mounted compressor units
- High Grade Stainless Construction Interior and Exterior
- Heavy duty compressor
- Pre fitted castors
- Magnetic door gaskets
- Easy to clean black plastic drawer handles
- Pre-installed castors
- Comes complete with gastronorm pans
- Good for the harshest environments
- Climate Class 5 product



MGF8450GR



MGF8451GR



MGF8453GR

Product Code	
MGF8450GR	Chef Base 215L
MGF8451GR	Chef Base 235L
MGF8453GR	Chef Base 340L

Under Broiler Counter's

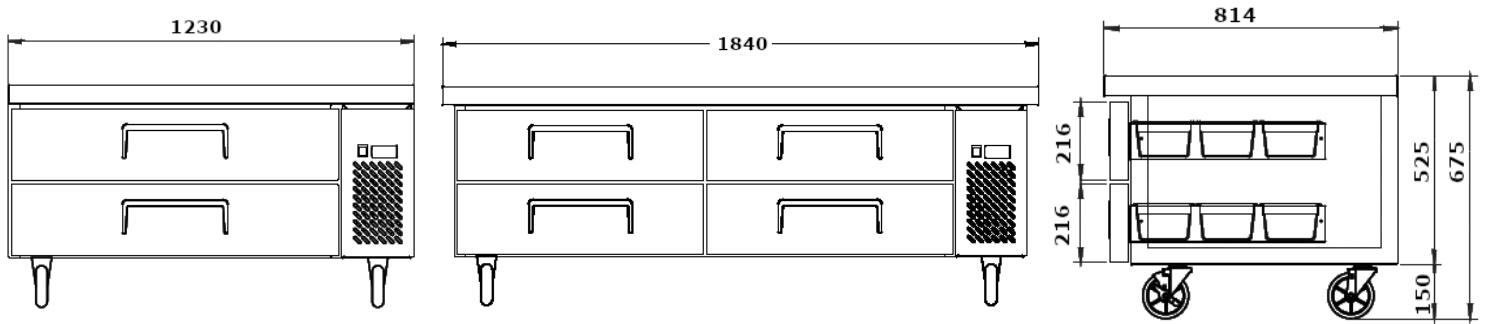

Model	MGF8450	MGF8451	MGF8453
Exterior Dimension (WxDxH) mm	1230 x 814 x 675	1322 x 814 x 675	1840 x 814 x 675
Interior Dimension (WxDxH) mm	922 x 650 x 424	1016 x 650 x 424	1461 x 650 x 424
Packing Dimension (WxDxH) mm	1285 x 885 x 735	1590 x 885 x 735	1895 x 885 x 735
Gastronorm Pan Capacity	1 x 2/1 & 3 x 1/6 per drawer (2 Drawers)	3 x 1/1 per drawer (2 Drawers)	1 x 2/1 per drawer (4 Drawers)
Shelf Quantity	N/A	N/A	N/A
Shelf Loading Capacity (Kg Pc)	N/A	N/A	N/A
Capacity (Litre)	215	235	340
Net Weight (Kgs)	100	104	140
Gross Weight (Kgs)	117	117	165
Voltage	220/50/1	220/50/1	220/50/1
Power (Watts)	300	300	300
Electrical Current (Amps)	1.7	1.7	1.7
KW/H Annum	520	520	830
Energy Efficiency Class	B	C	C
Climate Class	5	5	5
Defrost Method	Air Defrost	Air Defrost	Air Defrost
Refrigerant Type / Amount	R600a / 90g	R600a / 90g	R600a / 110g
Cooling Method	Ventilated	Ventilated	Ventilated
Inner Temperature (°C)	+2°C to +8°C	+2°C to +8°C	+2°C to +8°C
Insulation	Polyurethane	Polyurethane	Polyurethane
Foaming Material	C5H10	C5H10	C5H10
Castors	4 (2 Braked On Front)	4 (2 Braked On Front)	4 (2 Braked On Front)
Material External / Internal	S/S Int + Ext	S/S Int + Ext	S/S Int + Ext
Lighting	N/A	N/A	N/A
Door lock	N/A	N/A	N/A