

Product Dimension

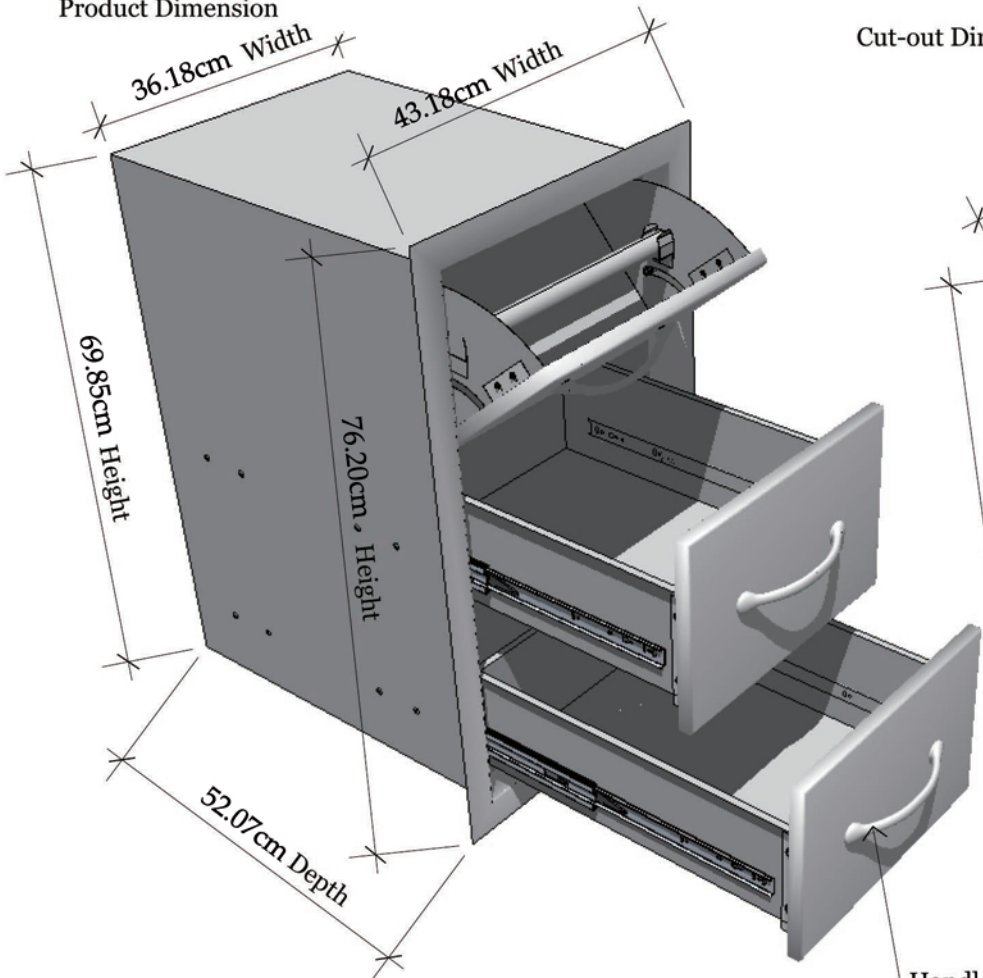

Cut-out Dimension

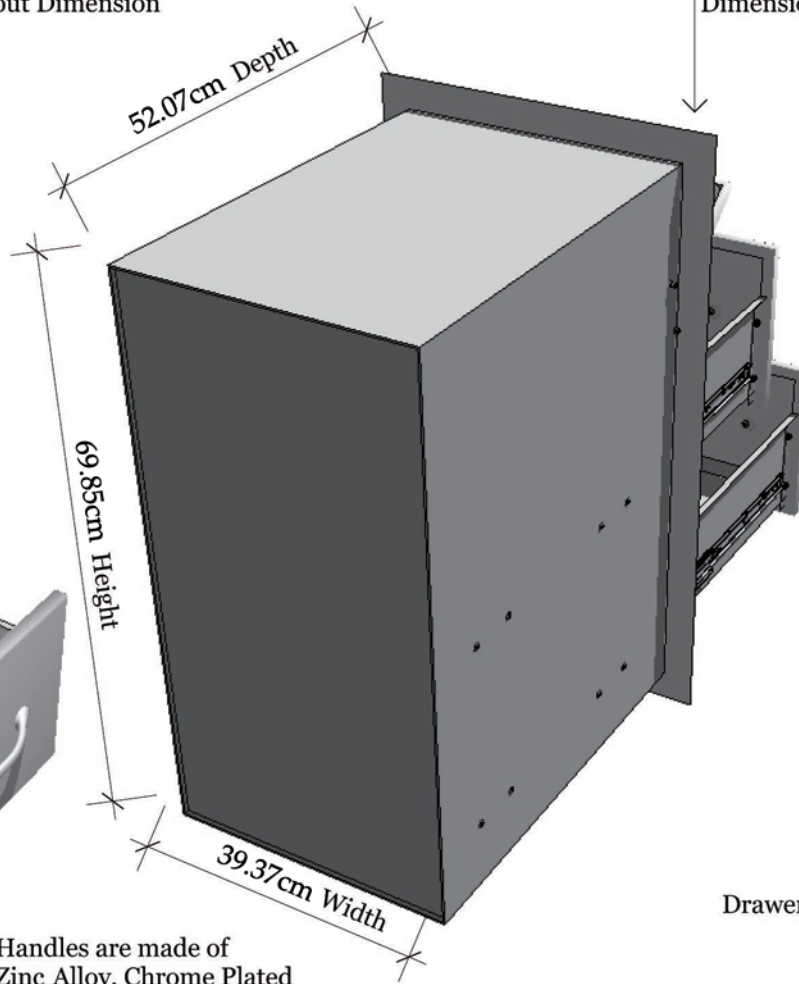

3.65cm Flange Dimension



Av. Combatentes do Ultramar, 184
2715-776 Lameiras, Sintra,
Portugal
Tel: (+351) 219 670 073
Email: info@sunstoneoutdoorkitchens.com

PRODUCT

Item No. A-DPCF

Drawer & Paper Towel Holder Combo
Product Size (cm): 43,1 W x 52 D x 76,2 H
Weight (kg): 24

Material Specifications:
16 gauge 304 stainless steel for frame.
18 gauge 304 for panel and sector.
20 gauge 201 for cabinet.
18 gauge galvanized sheet for the box.
Handles are made of zinc alloy, chrome plated.

Drawer Specifications

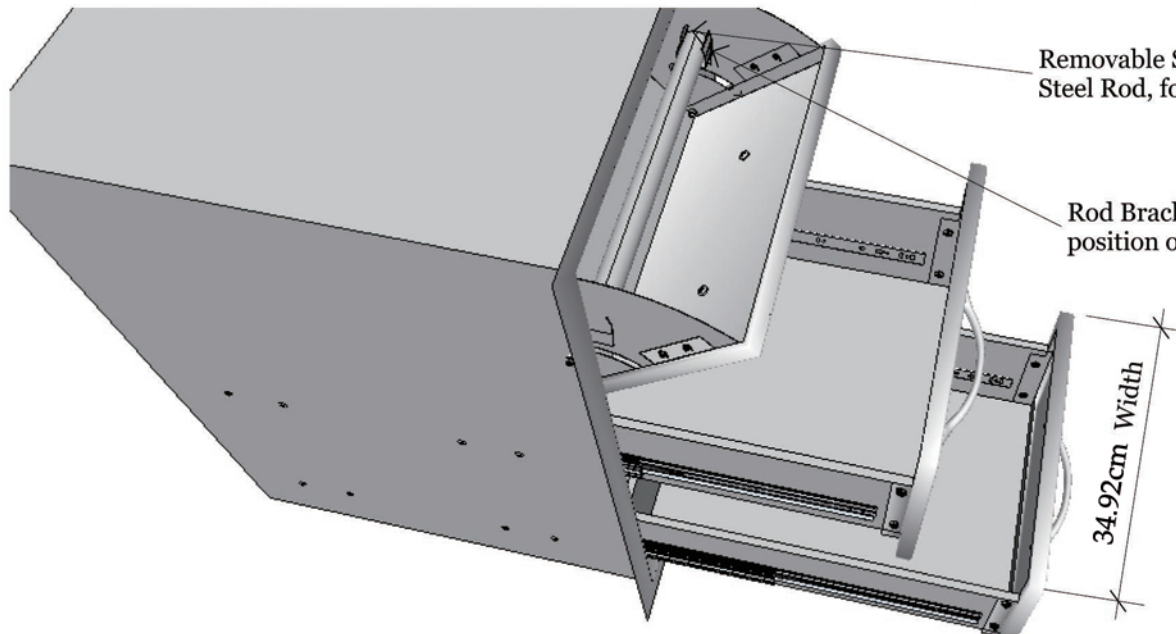

Handles are made of Zinc Alloy, Chrome Plated

Drawer Extension

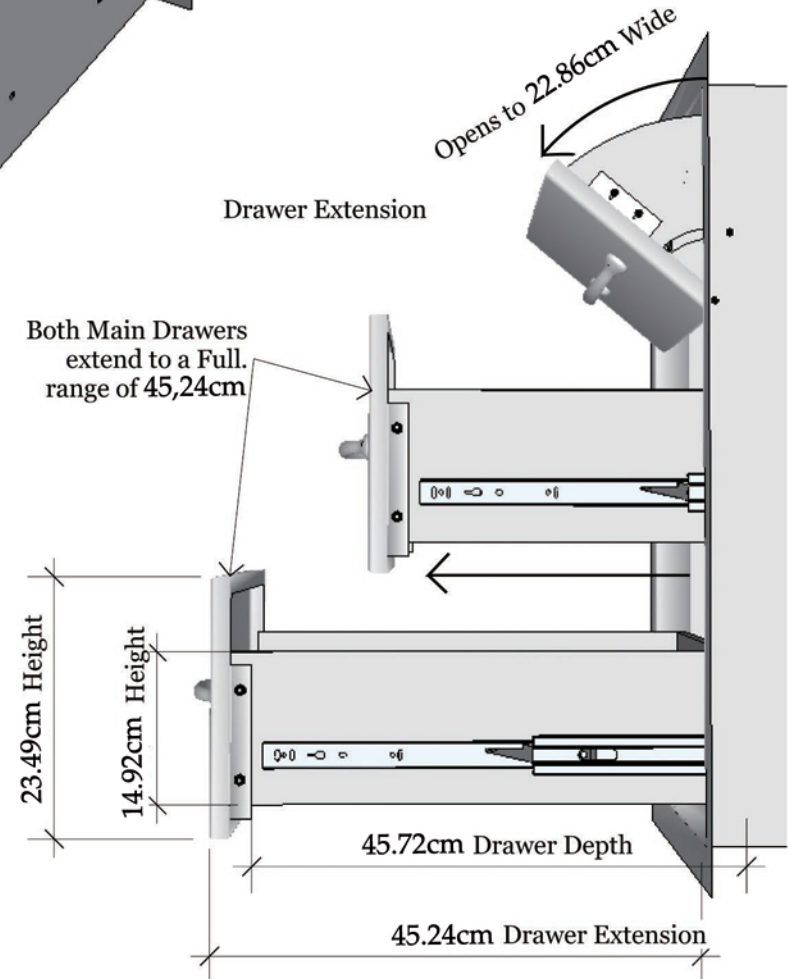

Both Main Drawers extend to a Full range of 45,24cm