

Preparation Units

Features

- High Grade Stainless Steel Construction Interior and Exterior
- Heavy duty Embraco compressor
- Self-closing and stay open door
- Gastro pans fitted as standard
- Air trickle vents over gastro pans
- Easy to clean black plastic door handle
- Magnetic door gaskets
- Pre-installed castors
- Pre-installed shelves
- Splash proof cover to control panel
- Climate Class 5 product
- Optional Marble tops
- Optional Crumb catchers
- Good for the harshest of environments



MSF8302



MSF8304



MPF8202



MPF8203

Product Code	
MSF8302 & GN Pans	2 Door Refrigeration Preparation Table Including 6 x 1/3 GN Pans/Lids 100mm Deep
MSF8303 & GN Pans	2 Wide Door Refrigeration Preparation Table Including 8 x 1/3 GN Pans/Lids 100mm Deep
MSF8304 & GN Pans	3 Door Refrigeration Preparation Table Including 9 x 1/3 GN Pans/Lids 100mm Deep
MPF8202 & GN Pans	2 Door Refrigeration Preparation Table Including 9x 1/3 GN Pan Option
MPF8203 & GN Pans	3 Door Refrigeration Preparation Table Including 12x 1/3 GN Pan Option

Optional Extras

Chopping Board Work Top As Standard - Marble Top Optional Extra



Description	Description
Marble Top for MSF8302	Marble Top for MPF8202
Marble Top for MSF8303	Marble Top for MPF8203
Marble Top for MSF8304	Crumb Catcher for MPF Models

Preparation Units

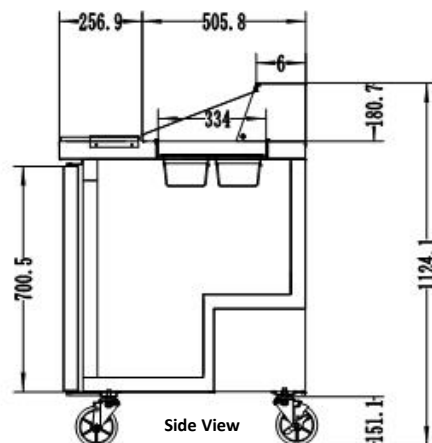
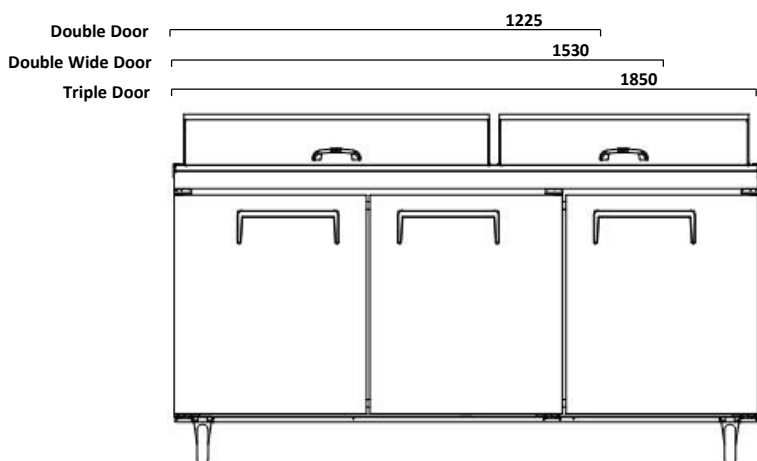

Model	MSF8302	MSF8303	MSF8304
Exterior Dimension (WxDxH) mm	1225 x 763 x 1124	1530 x 763 x 1124	1850 x 763 x 1124
Interior Dimension (WxDxH) mm	1135x598x677	1440x598x677	1756x598x677
Packing Dimension (WxDxH) mm	1295x851x1186	1600x851x1186	1916x851x1186
Shelf Dimensions mm	547x448	701x448	547x448/600x448
Shelf Quantity	2	2	3
Shelf Loading Capacity (Kg Pc)	40	40	40
Capacity (Litre)	379	487	598
Net Weight (Kgs)	110	150	170
Gross Weight (Kgs)	120	160	180
Voltage	220/50/1	220/50/1	220/50/1
Power (Watts)	370	370	430
Electrical Current (Amps)	2.6	2.6	2.9
Power Consumption (KW 24Hrs)	2.2	2.2	2.6
Climate Class	5	5	5
Defrost Method	Air Defrost	Air Defrost	Air Defrost
Refrigerant Type / Amount	R134a / 350g	R134a / 350g	R134a / 500g
Cooling Method	Ventilated	Ventilated	Ventilated
Inner Temperature (°C)	+2°C to +8°C	+2°C to +8°C	+2°C to +8°C
Insulation	Polyurethane foam	Polyurethane foam	Polyurethane foam
Foaming Material	C5H10	C5H10	C5H10
Castors	4 (2 Braked on front)	4 (2 Braked on front)	4 (2 Braked on front)
Material External / Internal	S/S Int + Ext	S/S Int + Ext	S/S Int + Ext
Lighting	No	No	No
Door lock	No	No	No

Preparation Units

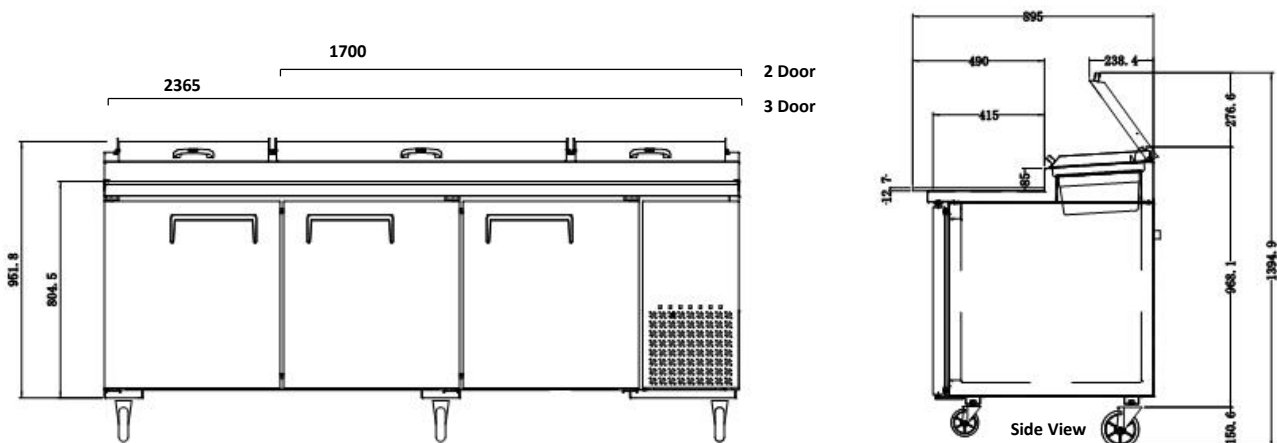

Model	MPF8202	MPF8203
Exterior Dimension (WxDxH) mm	1700 x 895 x 1395	2365 x 895 x 1395
Interior Dimension (WxDxH) mm	1612 x 670 x 670	2272 x 670 x 670
Packing Dimension (WxDxH) mm	1770 x 895 x 1153	2431 x 895 x 1153
Shelf Dimensions mm	604 x 651	604 x 651
Shelf Quantity	2	3
Shelf Loading Capacity (Kg Pc)	40	40
Capacity (Litre)	523	804
Net Weight (Kgs)	249	316
Gross Weight (Kgs)	259	330
Voltage	220/50/1	220/50/1
Power (Watts)	410	600
Electrical Current (Amps)	2.6	4
Power Consumption (KW 24Hrs)	2.5	3.6
Climate Class	5	5
Defrost Method	Air Defrost	Air Defrost
Refrigerant Type / Amount	R134a / 320g	R404a / 300g
Cooling Method	Ventilated	Ventilated
Inner Temperature (°C)	+2°C to +8°C	+2°C to +8°C
Insulation	Polyurethane foam	Polyurethane foam
Foaming Material	C5H10	C5H10
Castors	4 (2 Braked on front)	6 (3 Braked on front)
Material External / Internal	S/S Int + Ext	S/S Int + Ext
Lighting	No	No
Door lock	No	No