



CF450SS

Dimensions (mm)	External	Internal
Height	840	
Width	1270	
Depth	755	
Capacity (ltr)		
Gross		450
Net		354



CF550SS

Dimensions (mm)	External	Internal
Height	840	
Width	1530	
Depth	755	
Capacity (ltr)		
Gross		550
Net		439



CF650SS

Dimensions (mm)	External	Internal
Height	840	
Width	1810	
Depth	755	
Capacity (ltr)		
Gross		650
Net		537

Features

- White laminated exterior; stippled aluminium interior
- High grade 304 stainless steel lid with plastic capped ends, can be used as a work surface
- Roll bond maintenance free condenser
- Lock fitted as standard
- Rollers fitted as standard
- Replaceable door gasket

Additional Extras

- B9-BASKET - Basket for CF450/550/650
- B9-GASKET450 - Gasket for CF450
- B9-GASKET550 - Gasket for CF550
- B9-GASKET650 - Gasket for CF650



Technical Specification

	CF450S	CF550SS	CF650SS
Temperature Range	-18°C ~ -22°C	-18°C ~ -22°C	-18°C ~ -22°C
Climate Class	4	4	4
Power Supply	13amp	13amp	13amp
Cooling	Static	Static	Static
Defrost	Manual	Manual	Manual
Noise Level	48db	48db	48db
Refrigerant	R600a	R600a	R600a
Energy Efficiency Class	F	F	F
Energy Consumption (kw/24hrs)	0.81	0.92	0.97
Power Usage (w)	138	161	161
Weight (kg)	65.5	75	83.5

CF450SS

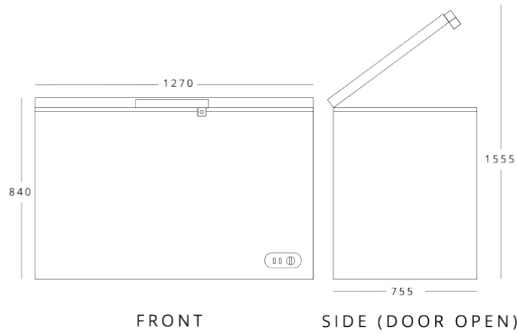

CF550SS

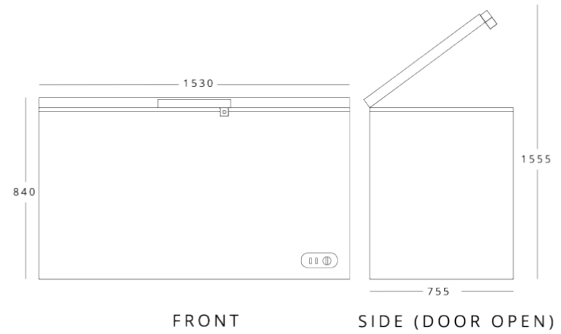

CF650SS-

