



CD100R

Dimensions (mm)	External	Internal
Height	1030	
Width	480	
Depth	480	
Capacity (ltr)		
Gross		100
Net		73



CD400R

Dimensions (mm)	External	Internal
Height	1750	
Width	680	
Depth	680	
Capacity (ltr)		
Gross		360
Net		235

Features

- Stainless Steel body base
- Brilliant Internal LED lighting at 2 sides
- 3 adjustable glass shelves
- Shelf rotatable manually
- Double tempered glass
- Self closing door

Additional Extras

- B4-SHELF100 - Glass shelf for CD100R
- B4-SHELF400 - Glass shelf for CD400R
- B4-GASKET400R - Gasket for CD400R



Technical Specification

	CD100R	CD400R
Temperature Range	+2°C ~ +8°C	+2°C ~ +8°C
Climate Class	4	4
Power Supply	13amp	13amp
Cooling	Vetilated	Vetilated
Defrost	Automatic	Automatic
Noise Level	55db	55db
Refrigerant	R600a	R600a
Energy Efficiency Class	C	C
Energy Consumption (kw/24hrs)	3.1207	7.201
Power Usage (w)	230	480
Weight (kg)	55	140

CD100R

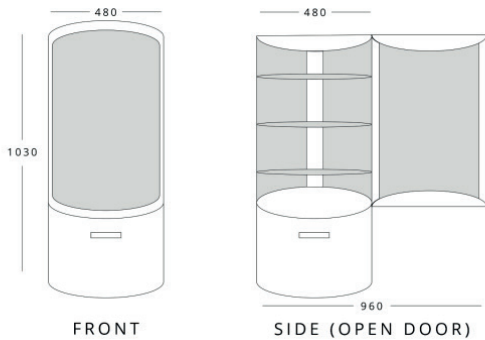

CD400R

