

FS-CT

FLEXI-SERVE CLEARING TROLLEY

Flexi-Serve mobile clearing trolley has been designed to be easily moved into position and has four braked castors to avoid movement whilst in operation. The unit features 3 removable bins, ideal for general waste or recycling and has lift off doors for easy access.



FLEXI SERVE

MADE IN BRITAIN

Model Specification	FS-CT
Dimensions (w x d x h) mm	1495x700x900
Total Power kW	N/A
Plug Type	N/A
Weight Packed (kg)	136
Weight Unpacked (kg)	108
Dimensions incl splashback	1495x700x1100

FEATURES

- Full length splashback
- 4 locking castors
- 3 scrap holes with rubber rings
- 3 removable bins included - ideal for general waste or recycling
- Lift off doors combine cleans looks with easy access
- Tray stand holds up to 350mm x 500mm
- Various fascia panel colours available

CLEARING TROLLEY

FS-CT LINE DRAWING

Dimensions in mm

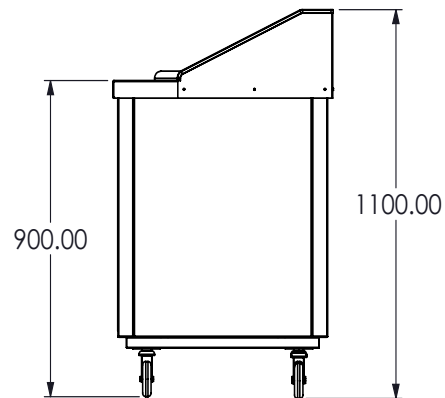
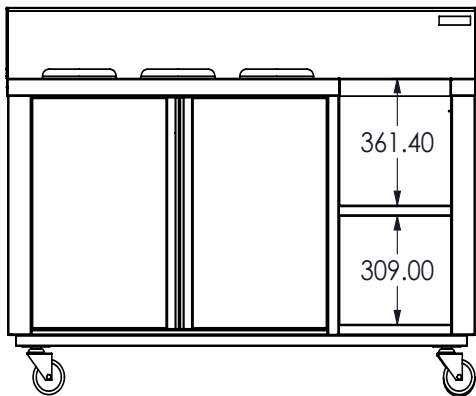
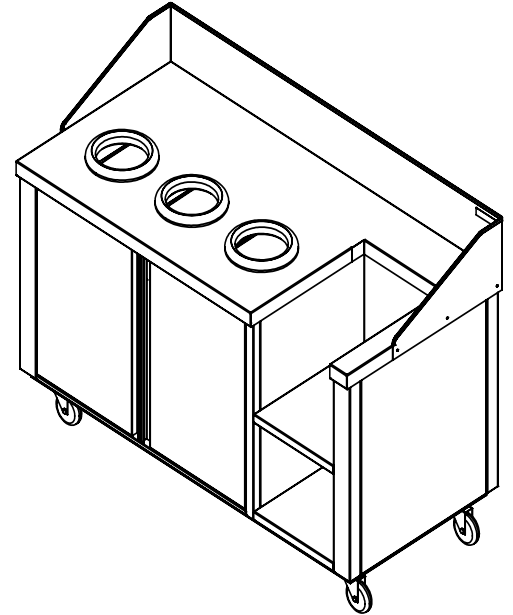
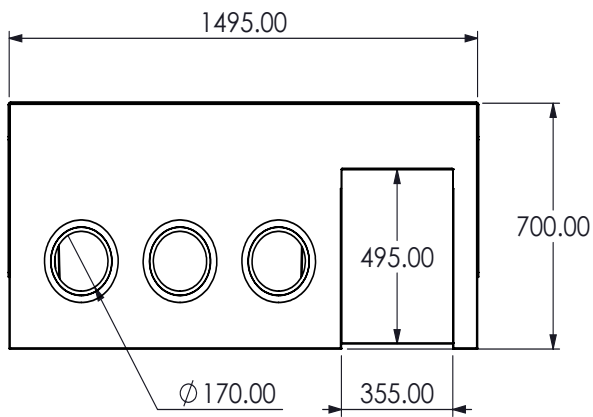

AVAILABLE ACCESSORIES

- N/A