



X-LARGE VOLUME DEEP FRYER - PRESSURE VAT - FILTER SYSTEM -
ELECTRIC OPERATION - TOUCHSCREEN CONTROLS -
TRAINING CENTRAL™

Model FKM-TC



This extra-large, electric pressure-fryer is designed for simple operation, long life, and high product volume. The results from pressure-frying are delicious! As pressure builds up in the vat, moisture in the protein is trapped, resulting in perfectly tender and moist meat that retains a crispy exterior. Pressure-fried foods have a longer holding life, too—great for grocery deli grab-n-go displays. Combine this fryer with a warmer, and your food will be hot and crispy for hours!

The BKI® TC series of high-volume deep fryers now feature touchscreen controls with our new, signature Training Central™. In minutes, new employees will be managing virtually every operation—programming, cooking, cleaning, filtering, boiling out, and more—simply by following intuitive, step-by-step screen instructions that provide instant feedback. Training Central reduces time spent on employee training and retraining to save you money.

The heating elements are completely submerged in oil inside the vat to maximize efficiency and speed recovery times. A cold zone in the vat collects breading fall-off to keep oil fresh, while the built-in filtration system extends oil life to save you money and produce consistent results. The patented quick-disconnect allows for easy removal of the vat, so filtering oil is easy and safe.

FEATURES AT A GLANCE

- 7" LCD touchscreen controls with Training Central
- USB for uploading recipes
- Heavy-duty, aluminum oil vat lid with rolled edges
- Electric operation
- 24 lb (10.8 kg) product with optional grande basket, 75 lb (34 kg) oil capacity
- Utilizes controlled low pressure
- Pressure-regulated lid interlock system
- 5" casters for easy mobility
- Stainless steel construction
- Built-in filtration
- Assembled in USA



PRESSURE COOKING

Pressure cooking results in moist and tender meat and longer holding life.



ELECTRIC OPERATION

Energy efficiency and easy installation are a perfect pairing for your food service operation.



TOUCHSCREEN CONTROLS

Intuitive touchscreen controls feature the Training Central.

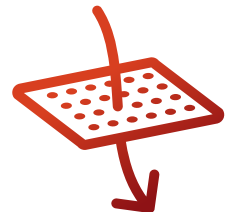

SEMI-AUTO FILTRATION

Semi-automatic filtration system filters after every batch without operator input.

www.bkideas.com

42 Allen Martin Drive, Essex Junction, VT 05452 • Phone: (802) 658-6600 • Fax: (802) 864-0183

BK1274 Rev C (8/21)

EQUIPMENT DIMENSIONS

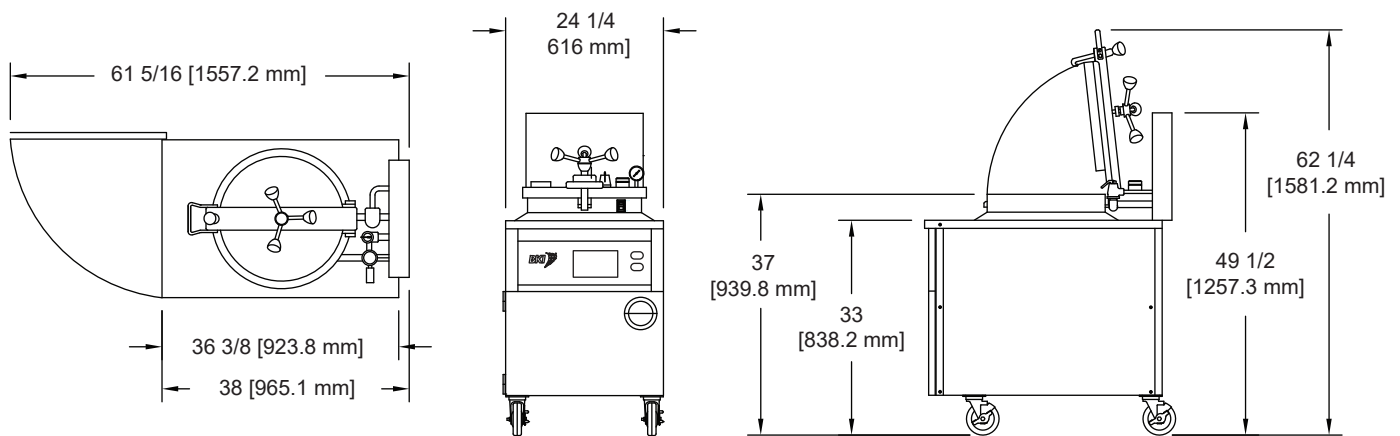

MECHANICAL SPECIFICATIONS

| Dimensions | Uncrated | Crated |
|-------------|----------------------|----------------------|
| Height | 49 1/2" (1257.3 mm) | 60" (1524 mm) |
| Width | 24 1/4" (616 mm) | 31" (787 mm) |
| Depth | 38" (965.1 mm) | 45" (1143 mm) |
| Floor space | 6.4 sq ft (.59 sq m) | 7.9 sq ft (.73 sq m) |
| Weight | 385 lb (174.6 kg) | 405 lb (184 kg) |

ELECTRICAL OPTIONS

| Volts | Amps | Breaker | kW | Wires | Phase |
|---------|------|---------|------|-------|-------|
| 208 | 47.3 | 60 | 17 | 3 | 3 |
| 240 | 37.5 | 50 | 14.3 | 3 | 3 |
| 480 | 41 | 50 | 17 | 3 | 3 |
| 220/380 | 21.7 | 30 | 14.3 | 4 | 3 |
| 230/400 | 22.8 | 30 | 15.6 | 4 | 3 |
| 240/415 | 23.7 | 30 | 17 | 4 | 3 |
| 240/480 | 20.5 | 30 | 17 | 4 | 3 |

OPERATING PRESSURE

| | |
|--------------------|--------|
| Operating PSI | 12 PSI |
| Safety Release PSI | 15 PSI |

INCLUDED ACCESSORIES

- Ball-handle basket
- One L-tipped brush
- One long black brush
- One short black brush
- One white drain brush
- 1 pair 13" insulated mitts
- Package of five filter papers
- High-flow oil pump



Visit www.bkideas.com to view all accessories available with this model.