



DOMINA PRO 900 - PASTA COOKERS

CPE98T



2 BOWLS, ELECTRIC TOP FOR HANGING VERSIO

TECHNICAL DATA:

External dimensions - WxDxH (cm)	80x90x58
Tank capacity (lt-GN)	40+40
Total power (kW)	9+9=18
IPX5	●

ADDITIONAL TECHNICAL DATA:

Tank dimensions - WxDxH (cm)	30,5x51x27,5
Supply (N)	400V 3N 50/60Hz
Weight (kg)	75
Volume (m3)	1

The moulded tanks are in AISI 316 anti-corrosion stainless steel, with rounded corners for easy cleaning. The optional pasta baskets are in AISI 304 18/10 stainless steel with thermal handle. Electric valve to load the water.

Gas versions: stainless steel burner with self-stabilizing flame. Thermocouple safety device connected to the pilot flame. Piezo-electric burner ignition.

Electric versions: electric heating elements in armoured stainless steel; power adjustment with four position switch; control of the temperature with operating and safety thermostat.

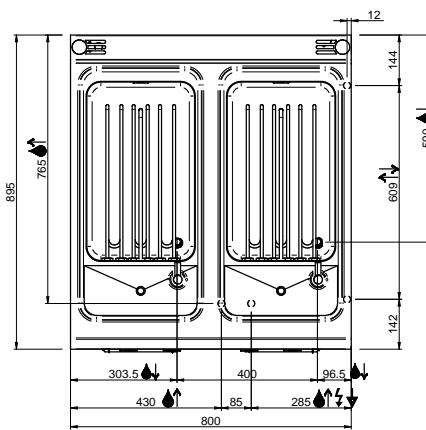
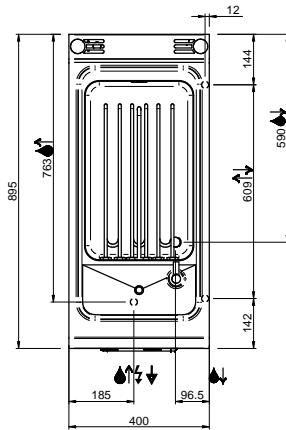
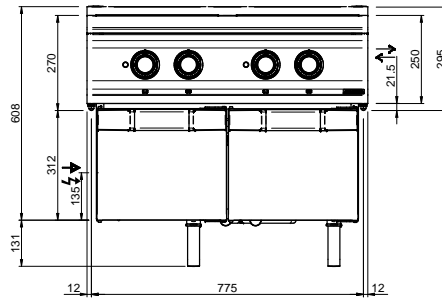
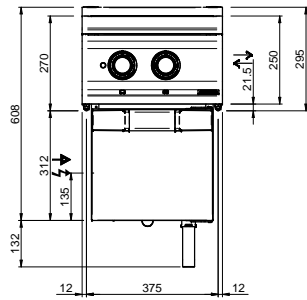

LEGENDA SIMBOLI / LEGEND



INGRESSO GAS / GAS INLET
(EN 10226-1) Ø M 1/2"



INGRESSO ACQUA /
WATER INLET Ø M 1/2"



ATTACCO EQUIPOTENZIALE /
EQUIPOTENTIAL



ALIMENTAZIONE ELETTRICA /
POWER SUPPLY



SCARICO ACQUA / OLII
WATER / OILS DRAIN



REGOLAZIONE PIEDINI /
FEET ADJUSTMENT (h 0/+50)
/ TOP VERSION (h 0/+5)