



DOMINA PRO 700 - BASES

BR773C



REFRIGERATED VENTILATED

TECHNICAL DATA:

External dimensions - WxDxH (cm)	160x70x60
----------------------------------	-----------

ADDITIONAL TECHNICAL DATA:

Weight (kg)	115
-------------	-----

Volume (m3)	0,9
-------------	-----

The DOMINA PRO 700 cupboard bases consists of different models dimensions.

The DOMINA PRO 700 range of ventilated refrigerated bases consists of models with 2/3 drawers or 2/3 doors. They are designed to carry cooking top units.

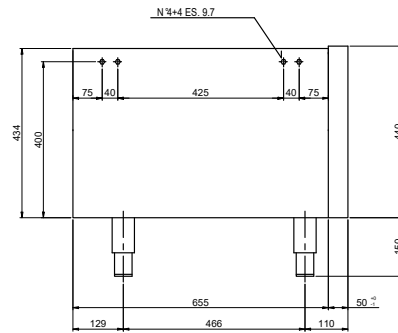
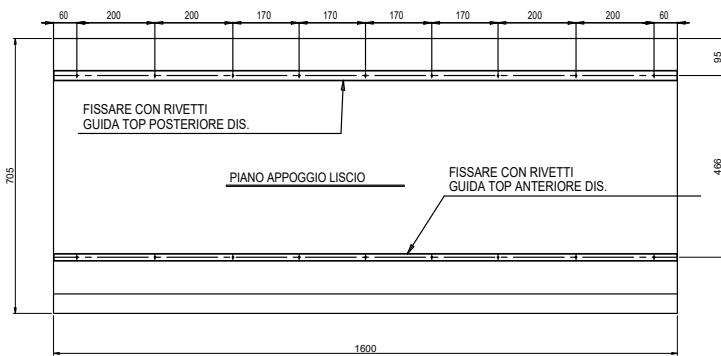
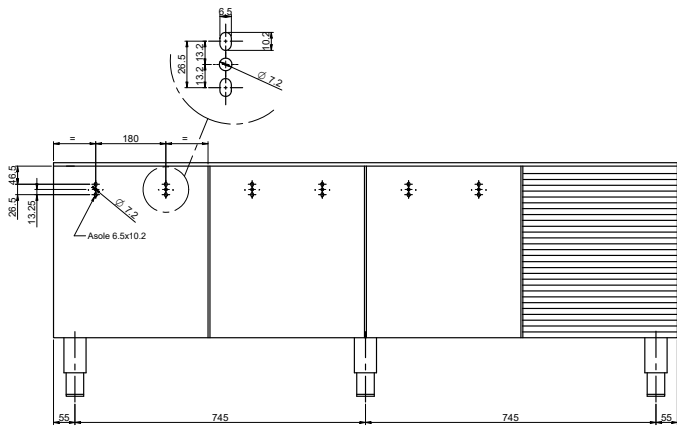

- BASE REFRIGERATA DOMINA PRO 700 / Refrigerated base Domina PRO 700
- N°3VANO GASTRONORM 1/1 / n.2 gastronorm 1/1 cupboards
- RIVESTIMENTO AISI 304 SCOTCH BRITE / AISI 304 s/s scotch brite
- N°4 INSERTI ES.M6 SU LATO DX. E SX. / n.4 inserts M.6 on right and left sides
- N°1 GUIDA TOP ANTERIORE FISSATA SUL COPERCHIO / n.1 front top guide fixed on the lid
- N°1 GUIDA TOP POSTERIORE FISSATA SUL COPERCHIO / n.1PO back top guide fixed on the lid

BASE REFRIGERATA 3P L=1600

FTF0002111