



HCL9 - Lincat Silverlink 600 Free-standing Heated Pedestal with Legs and Doors - W 900 mm - 1.0 kW

Designed to suite with other products in the Silverlink 600 range, the Heated Pedestal (top and legs) features an on/off switch and thermostatic control, making it ideal as a plate warmer.

- ✔ Designed to suite with the Silverlink 600 range
- ✔ Features an on/off switch and thermostatic control, making them ideal as plate warmers
- ✔ Silverlink 600 counter-top units are securely attached to pedestals by means of fixing screws supplied
- ✔ Adjustable shelf provides flexibility for storing bulky items
- ✔ Adjustable legs for perfect alignment even on uneven floors
- ✔ Doors are designed to fit left or right handed for flexibility in kitchen planning

Specifications

Summary

Brand	Lincat
Range	Silverlink 600
Power Type	Electric
Unit Type	Free-standing
Available in UK Only	No
UK Warranty	2 Years Parts and Labour Warranty
Export Warranty	Contact your local dealer
GTIN	5056105101000

Power and Performance

Total Power kW	1.00
Temperature Range °C	70 [constant]
Temperature Control	Mechanical

Key Specifications

Number of Shelves included	1
Number of Shelf Positions	3

Weights and Dimensions

Unit Height (External) mm	668
Unit Width (External) mm	900
Unit Depth (External) mm	600
Height (Internal) mm	422
Width (Internal) mm	898
Depth (Internal) mm	566
Shelf Dimensions Width mm	850
Shelf Dimensions Depth mm	530
Net Weight Kg	37.4

Supply Connections

Requires Installation	No
Requires Electrical Supply	Yes
UK 3 Pin Plug	Yes
Requires Hardwiring	No
Electrical Supply Rating Watts	1,000
Single Phase Amps	4.3
Single Phase Voltage	230

Shipping

Packed Weight Kg	41.14
Packed Height cm	77
Packed Width cm	98
Packed Depth cm	81

Available Accessories

PSH9	900 PEDESTAL SHELF
-------------	--------------------

Technical Picture

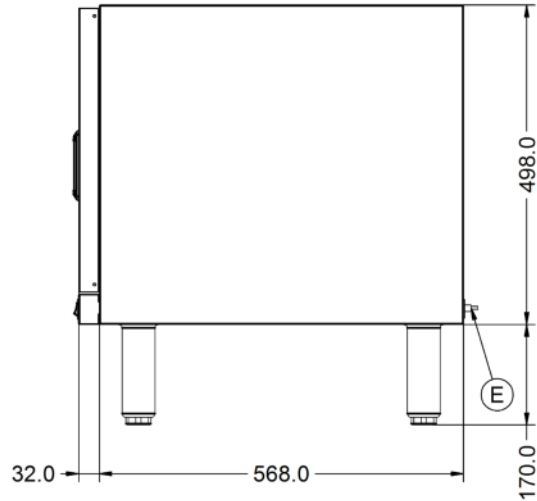
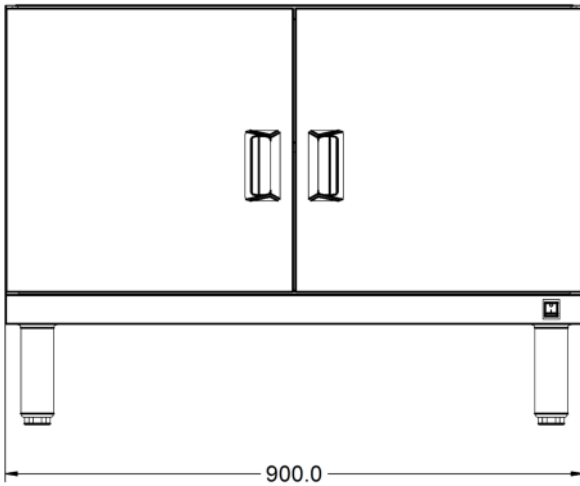
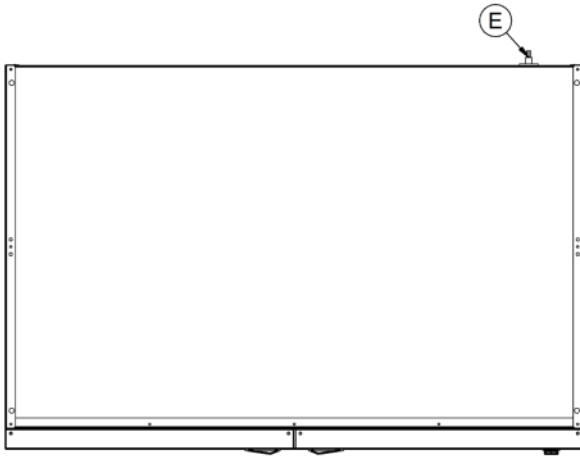

Lincat Limited

Whisby Road,
Lincoln, LN6 3QZ,
United Kingdom

Company No: 2175448

A member company of



Customer Care

Tel: +44 1522 875500
Email: care@lincat.co.uk

Export Customers

Tel: +44 1522 875536
Email: export@lincat.co.uk

Opening Hours

Monday – Friday:
8.30am – 5pm