



F59/730 - IMC MF15 Free-standing Vegetable Peeler - with Onion Plate - 1 Phase - W 481 mm - 0.37 kW

The high-output, versatile MF15 Onion Peeler (1PH) can be used to quickly peel onions - making it an ideal addition for medium to large kitchens.

- ✓ Able to peel up to 202kg of onions per hour - in 15kg batches.
- ✓ Adjustable timer ensures accurate, repeatable peeling times.
- ✓ Smooth stainless steel waste outlet prevents blockages and build-up of peelings.
- ✓ Modular construction facilitates easy maintenance.
- ✓ Interlocking lid and door ensure safe operation.
- ✓ Thicker peeling plate delivers longer operating life.
- ✓ Perspex viewing pane allows you to monitor the peeling progress.
- ✓ Suitable for medium to large kitchens with single-phase power supply.

Specifications

Summary

Brand	IMC
Range	MF Multi-Functional Peeler
Power Type	Electric
Unit Type	Free-standing
Available in UK Only	No
UK Warranty	2 Years Parts and Labour Warranty
Export Warranty	Contact your local dealer
Mounting	Free-standing
GTIN	5056105198727

Power and Performance

Total Power kW	0.37
HP	0.5
IP Rating	IP55

Key Specifications

Operator Safety	Interlocks
Timer	Yes
Drain Location	Rear and under
Airbreak	Yes

Capacity

Capacity Kg per Hour	202
-----------------------------	-----

Weights and Dimensions

Unit Height (External) mm	1171
Unit Width (External) mm	481
Unit Depth (External) mm	629
Net Weight Kg	51.5

Supply Connections

Requires Installation	Yes
Requires Electrical Supply	Yes
UK 3 Pin Plug	No
Requires Hardwiring	Yes
Motor Rating Watts	370
Single Phase Amps	3.6
Single Phase Voltage	230
Water Connection Pressure Bar	2.7-3.8 [40-55 psi]
Drain Connection	38mm
Water Connection	12mm

Shipping

Packed Weight Kg	62.5
Packed Height cm	125
Packed Width cm	68
Packed Depth cm	51

Available Accessories

- S58/062** Inlet Hose Kit for MF10/MF10L/MF15/MF15L Vegetable Peeler
- S59/166** Onion Peeling Plate for MF10/MF15 Vegetable Peeler

Technical Picture

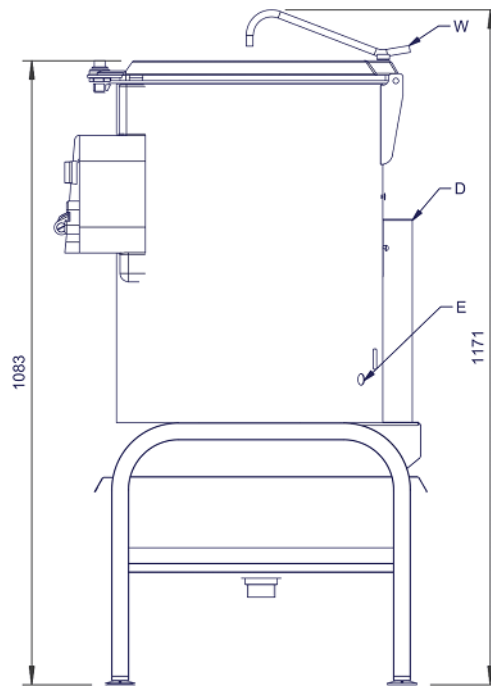
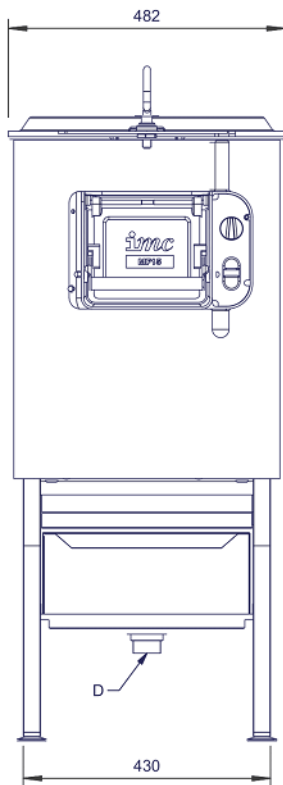
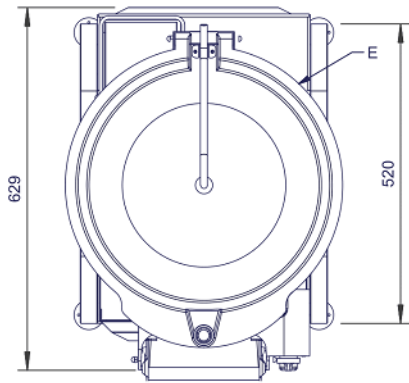



Lincat Limited

Whisby Road,
Lincoln, LN6 3QZ,
United Kingdom

Company No: 2175448

A member company of



Customer Care

Tel: +44 1522 875500
Email: care@lincat.co.uk

Export Customers

Tel: +44 1522 875536
Email: export@lincat.co.uk

Opening Hours

Monday – Friday:
8.30am – 5pm