

Original instruction

INSTRUCTION MANUAL

Blast Chiller Cabinets



Please read the user's manual before you use this product

Blast Chiller Cabinets

Installation, use and maintenance instructions

1. INTRODUCTION	2
2. The manufacturer cannot be held liable in the following cases:.....	3
3. TRANSPORTATION AND STORAGE	3
4. COMMISSIONING.....	4
4.1 POSITIONING.....	4
4.2 INITIAL CLEANING	5
4.3 Electrical connection	5
4.4 CONNECTION TO DRAINS.....	5
5. TECHNICAL CHARACTERISTICS.....	6
5.1 NOISE AND VIBRATION	6
5.2 POSSIBLE USAGES.....	6
6. USAGE.....	7
6.1 ACTION.....	7
6.2 Meaning of the button	7
6.3 Selecting the BLAST CHILLING cycle.....	8
6.4 How to access and set parameters.....	9
6.5 Accessing the parameters divided by functional blocks	10
6.6 Directly accessing the parameters by selecting the category.....	10
6.7 Alarms with manual reset.....	10
6.8 HACCP function	10
6.9 Procedure for setting the default parameter values.....	11
7. MANITENANCE.....	11
7.1 PERIODIC CLEANING	11
7.2 CLEANING OF CONDENSER	11
7.3 PERIOD OF INACTIVITY OF CABINET	11
8. TROUBLE SHOOTING AND REMEDIES.....	12
8.1 If the cabinet does not operate, make sure that:.....	12
8.2 If the required temperature is not achieved, make sure that;.....	12
8.3 If the cabinet leaks water, make that:	12
8.4 If the cabinet is unacceptably noisy, make sure that:.....	12
8.5 IMPROBABLE RISKS	12
9. SUBSTITUTION OF SPARES	12
10. DISMANTLING.....	12
Circuit diagram	14
Technical Parameters.....	15
OFFICIAL APPROVAL AND RULES.....	15
Summary of operating parameters.....	16
Signals on the display	16
CORRECT DISPOSAL OF THIS PRODUCT	17

1. INTRODUCTION

Please read instructions before using this appliance.

IMPORTANT SAFETY INSTRUCTION

- ▲ To reduce the risk of fire, electric shock, or injury to persons when using your product, basic safety precautions should be followed, including the following.
- ▲ This appliance must be properly installed and located in accordance with the Installation Instruction before it is used.
- ▲ Before the appliance is plugged in, ensure that the rated voltage corresponds to the voltage of the electrical system in your home. The power plug should have its own independent socket. Using adapters may cause overheating or burning.
- ▲ This appliance can be used by children aged from 8 years and above and persons with reduced physical, sensory or mental capabilities or lack of experience and knowledge if they have been given supervision or instruction concerning use of the appliance in a safe way and understand the hazards involved.
- ▲ Children shall not play with the appliance.
- ▲ Cleaning and user maintenance shall not be made by children without supervision.
- ▲ If the supply cord is damaged, it must be replaced by the manufacturer or its service agent or a similarly qualified person in order to avoid a hazard.
- ▲ Connect to properly grounded outlets only. Avoid the use of extension cords. Do not run cord under carpeting, runners or the like. Arrange cord away from traffic area and where it will not create a tripping hazard.
- ▲ Always unplug appliance when not in use and before cleaning, adjusting or maintaining this machine. To disconnect appliance, turn switch off and remove plug from power source.
- ▲ Do not disconnect by pulling on the cord. Always disconnect by grasping and pulling on the plug top.
- ▲ Do not pull out the cord or touch the power plug with wet hands. Clean water or dust from the power plug and insert it with the ends of the pins securely connected.
- ▲ Do not use outdoors.
- ▲ Do not splash water on the appliance. It may cause a malfunction or electric shock.
- ▲ Do not disassemble, repair or alter the appliance. It may cause fire or abnormal operations, which may lead to injury.
- ▲ After your fridge-freezer is in operation, do not touch the cold surfaces in the freezer compartment, particularly when hands are damp or wet. Skin may adhere to these extremely cold surfaces.
- ▲ Never place glass products in the freezer because they may be broken when their inner contents are frozen.
- ▲ The refrigerant and insulation blowing gas used in the appliance require special disposal procedures. When disposal, please consult with service agent or a similarly qualified person.
- ▲ Do not store explosive substances such as aerosol cans with a flammable propellant in this appliance.
- ▲ If you need the electronic version instruction manual, please ask the manufacturer or its service agent .
- ▲ Max. Load of shelf is 88 lbs.
This instruction manual provides all the necessary information regarding:
 - ▲ use of the refrigerator

- ▲ technical specifications
- ▲ installation and handling
- ▲ operator procedures and instructions
- ▲ maintenance operation

The manual is to be considered an integral part of the refrigerator and should be stored in a safe place for future consult to permit a good working life of the refrigerator.

The appliance is intended for commercial use only.

2. The manufacturer cannot be held liable in the following cases:

- improper installation (not in accordance with the guidelines indicated herein)
- misuse of the refrigerator
- power supply defects
- improper or inadequate maintenance
- unauthorised modification or tampering
- use of non-original spare parts
- partial or total failure to comply with the instructions

All electrical equipment can be hazardous to health. Current standards and legal requirements must be complied with during the installation and use of any equipment.

3. TRANSPORTATION AND STORAGE

The equipment is wrapped in absorbent material and contained and fixed within a wooden platform and paper box.

Whilst awaiting by definitive collection, these should be stored within a protected and covered environment at a temperature between -25°C / $+55^{\circ}\text{C}$, with ambient humidity between $30^{\circ}\text{C}/95\%$. Do not stack more than three items.

4. COMMISSIONING

Carefully read the label on the equipment, do not cover for any reason whatsoever. and replace them immediately if damaged. Do not remove protection or panelling that require the usage of tools.

4.1 POSITIONING

Ensure that in respect of the dimensions, the space reserved for the equipment permits its correct utilisation and ease of maintenance. After carefully unpacking the display case, remove the white PVC protective film and all of the manufacturer's material which safeguards the item in transit. Place the cabinet on a flat surface and level it by screwing and adjusting the leveling legs to ensure its efficient operation. The cabinet must be lifted only from the exterior of the base to avoid the possibility of damage. Do not move the cabinet by application of pressure to the surface. if the device has been positioned horizontally (integral condensing unit).wait two hours before activating it. Packing and protective film should be disposed off as indicated by the local authorities. The equipment must not be installed within explosive ambience, In the open air or exposed to

Ensure that in respect of the dimensions, the space reserved for the equipment permits its correct utilisation and ease of maintenance. After carefully unpacking the display case, remove the white PVC protective film and all of the manufacturer's material which safeguards the item in transit. Place the cabinet on a flat surface and level it by screwing and adjusting the leveling legs to ensure its efficient operation. The cabinet must be lifted only from the exterior of the base to avoid the possibility of damage. Do not move the cabinet by application of pressure to the surface. if the device has been positioned horizontally (integral condensing unit).wait two hours before activating it. Packing and protective film should be disposed off as indicated by the local authorities. The equipment must not be installed within explosive ambience, In the open air or exposed to rain the correct siting is; distant from direct sources (radiators, direct lighting, etc...) and protected from direct sunlight and draughts. Air circulation must be freely maintained around the condensing unit, be it integral or remote. In observance of these specific conditions will detrimentally affect the cabinet. nsure that in respect of the dimensions, the space reserved for the equipment permits its correct utilisation and ease of maintenance. After carefully unpacking the display case, remove the white PVC protective film and all of the manufacturer's material which safeguards the item in transit. Place the cabinet on a flat surface and level it by screwing and adjusting the leveling legs to ensure its efficient operation. The cabinet must be lifted only from the exterior of the base to avoid the possibility of damage. Do not move the cabinet by application of pressure to the surface. if the device has been positioned horizontally (integral condensing unit).wait two hours before activating it. Packing and protective film should be disposed off as indicated by the local authorities.

The equipment must not be installed within explosive ambience, In the open air or exposed to rain the correct siting is; distant from direct sources (radiators, direct lighting, etc...) and protected from direct sunlight and draughts. Air circulation must be freely maintained around the condensing unit, be it integral or remote.

In observance of these specific conditions will detrimentally affect the cabinet.

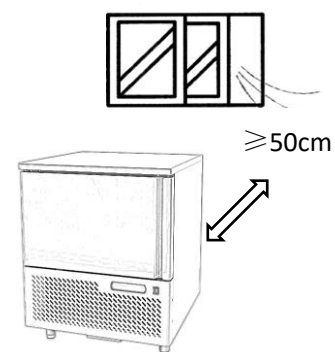

4.2 INITIAL CLEANING

Before use all parts of the cabinet should be cleaned, For the walls and all the internal parts use an antibacterial detergent. For the plastic parts use a moistened cloth. Dry with a soft clean cloth. use little or no water.

Do not use harsh or abrasive solvents or detergents During cleaning do not approach bare-handed those parts which could cut (evaporator, condenser, etc.) and always use protective gloves.

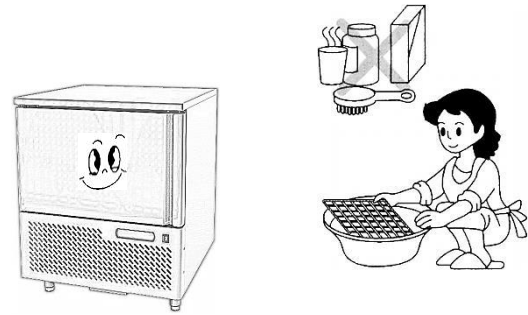

4.3 Electrical connection

Check that the supply conforms to the requirements listed on the factory label and that it is provided with a fall-safe protection or automatic circuit breaker with an efficient earth connection. Should there not be an electrical safety feature have this introduced by a qualified person.

by means of a omnipolar switch as indicated in the safety regulations with a means of a omnipolar switch as indicated in the safety regulations with a minimum clearance of the contacts of 3 mm. where the cabinet has to be installed at some distance from the electrical source. ensure that the conforms to the local regulations. Cabinet supplied with integral condensing units are provided with an appropriate plug fitted with a neutral and earth; the supply cable must be well stretched (avoid coiling and superimposition). it must not be exposed to the possibility of damage by third parties. it should not be in contact with liquids, water or heat sources. in the event of damage it must be replaced by qualified personnel. Always avoid the use of reducers or adapters.

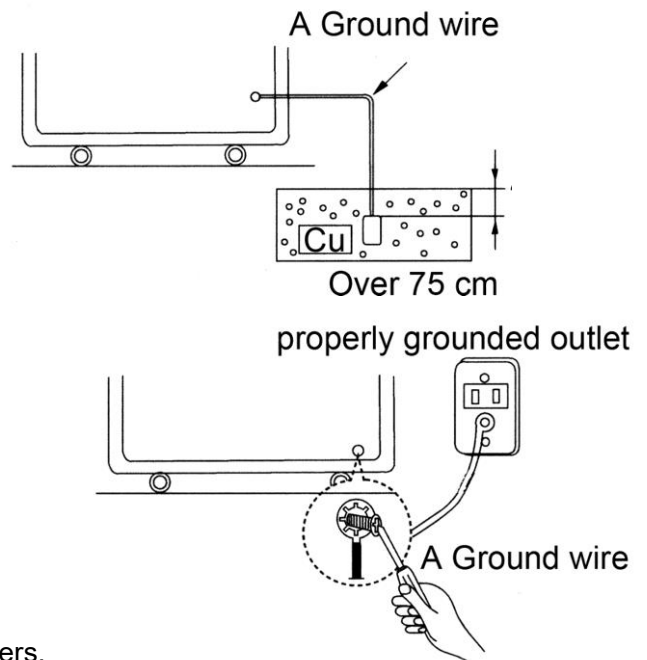
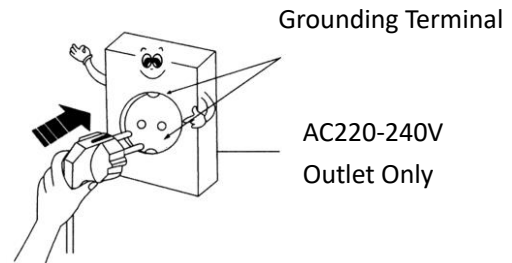

4.4 CONNECTION TO DRAINS

The dispersal of defrost water is automatic in all models with integral condensing unit.



5. TECHNICAL CHARACTERISTICS

5.1 NOISE AND VIBRATION

The sound level of the equipment fitted with integral hermetic condensing unit does not exceed 70 dB, it is therefore not necessary to provide sound insulation. Under normal conditions the equipment does not generate vibrations which affect surroundings.

5.2 POSSIBLE USAGES

Do not utilise the equipment to store medical supplies. the optimum operational ambient temperatures are between +10°C/ +32°C





6. USAGE

6.1 ACTION

These devices are activated by one switches and an electronic control panel.

6.2 Meaning of the button

if pressed for more than 3 seconds, switches the unit on/off		if pressed for more than 2 s, terminates the cycle and starts conservation : • if the cycle was CHILL: set point = 2 °C • if the cycle was FREEZE: set point = -20 °C
if pressed for more than 1 second, activates/deactivates auxiliary output 2 Inside light: if present, this button switches the inside light on/off		if pressed for more than 1 second, activates/deactivates auxiliary output 2 Inside light: if present, this button switches the inside light on/off
accesses the menu to display and delete the HACCP alarms		accesses the menu to display and delete the HACCP alarms
if pressed for more than 1 second, activates/deactivates auxiliary output 1 Pass-through probe: if configured, the heating cycle starts.	<i>aux</i>	if pressed for more than 1 second, activates/deactivates auxiliary output 1 Pass-through probe: the heating cycle does NOT start in any case.
if pressed for more than 3 seconds, accesses the password settings menu to access the type "F" (Frequent) or "C"(Configuration) parameters	<i><u>prg</u></i> <i>mute</i>	Parameter editing is not enabled.
mutes the audible alarm (buzzer) and deactivates the alarm relay		mutes the audible alarm (buzzer) and deactivates the alarm relay
if pressed for more than 3 seconds, starts/stops a manual defrost		Defrost button is not enabled.
if pressed for more than 1 second, accesses the menu for selecting the blast chilling cycle	<i>new</i> ►►	pushing the "new" button, the last cycle selected by the user is displayed for 3 seconds. pushing the "new" button again, the air temperature is displayed for 3 seconds.
starts the selected cycle, see the new button	►►start	If pressed, puts the cycle in standby. • Standby is indicated by flashing "Stb" (Maximum stand by function time). • Compressor and fan stop If pressed during standby, the cycle resumes from the point where it was stopped. Parameter "Stb" is used as a time limit for "standby" status: if standby status is longer than "Stb", the cycle restarts automatically from the beginning

6.3 Selecting the BLAST CHILLING cycle

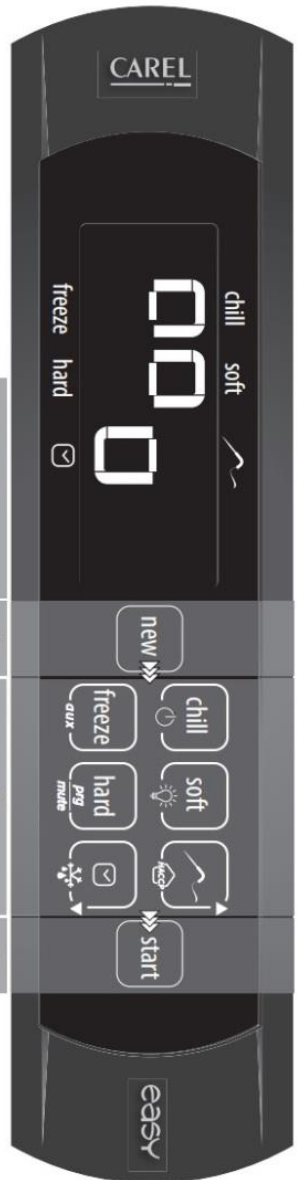

Selezione del ciclo ABBATTIMENTO

Entrata nel menù di selezione cicli:
Premiere il bottone NEW per 1 secondo
Il display visualizza l'ultimo ciclo completato.
Questo ciclo può essere lanciato immediatamente: **passare allo STEP 3**

Selezione dei cicli di abbattimento:
Premiere i bottoni di selezione. Premendo il bottone NEW si va allo STEP 1
Ogni singola scelta è visualizzata sul display con la relativa "o". Vedi tabella sotto.

Avvio del ciclo selezionato:
Premiere il bottone START per 2 secondi

Per annullare la selezione in corso: Non premere alcun bottone per 10 sec.



Selecting the BLAST CHILLING cycle

Access the cycle selection menu:
Press NEW for 1 second
The display shows the last completed cycle.
This cycle can be started immediately: **go to STEP 3**

Select the blast chilling cycle:
Press the selection buttons
Pressing NEW goes to STEP 1
Each individual selection is shown on the display with the corresponding "o". See the table below.

Start the selected cycle:
Press START for 2 seconds

To cancel the current selection: press no button for 10 seconds

	PHASE 1			PHASE 2			AUTOMATIC	
	ambient	product	time	ambient	product	time		
0000	0 °C	3 °C	90 min				NO	2° C
0000	-20 °C	10 °C	60 min	0 °C	3 °C	30 min	NO	2° C
0000	0 °C	-	90 min				NO	2° C
0000	-20 °C	-	60 min	0 °C	-	30 min	NO	2° C
0000	0 °C	3 °C	120 min	-35 °C	-18 °C	120 min	YES	-20° C
0000	-35 °C	-18 °C	240 min				YES	-20° C
0000	0 °C	-	120 min	-35 °C	-	120 min	YES	-20° C
0000	-35 °C	-	240 min				YES	-20° C

6.4 How to access and set parameters

type "F" (FREQUENT, not protected by password), type "C" (CONFIGURATION, password protected)

Step	Action	Effect	Meaning
1	Press PRG for 3 seconds	After 3 seconds the display will show the 1st parameter, "0"(Password)	Access to type "F" parameters is direct without password
2	Press UP or DOWN	The value on the display will increase or decrease.	Enter the password "22" to access the type "C" parameters or whatever different value for the type "F" parameters.
3	Press START	The display will show "St" (Setpoint)	This is the current value of the Setpoint
4	Press UP or DOWN	If the password set is 22 the display will scroll the list of type "C" parameters(CONFIGURATION) otherwise the list of type "F" parameters(FREQUENT)	Set the desired value
5	Press START	The display will show the parameter name	This is the current value of the parameter
6	Press UP or DOWN	The value on the display will increase or decrease	Set the desire value
7	Press START	The display will show the parameter name again	IMPORTANT: parameters not yet saved
8	Repeat steps 2,3,4&5 for all parameters required		
9	Press PRG for 5 seconds	The controller will display the temperature read by the probes again	IMPORTANT: only now have all the parameters been updated

For both types of access (type "F" and type "C") there is a timeout (no button on the keypad pressed for 1 min), the procedure is ended without saving the parameter.









6.5 Accessing the parameters divided by functional blocks

Once having accessed the type “F” or “C” parameters (see tables above)

Step	Action	Effect	Meaning
1	Press PRG	The display will show the name of the functional block that the parameter belongs to	Example ‘CMP’ for the compressor parameters, ‘dEF’ for the defrost parameters
2	Press UP or DOWN	The display will show the name of the other functional blocks	Example ‘Fan’ for the fan parameters
3	Press START	The display will show the name of the first parameter in the functional block selected	Example “F0” for ‘Fan’

6.6 Directly accessing the parameters by selecting the category

The configuration parameters can also be accessed, in addition to the mode described above, via the category (see the icons and abbreviations in the table below), according to the list on the display with the corresponding name and icon. To directly access the list of parameters grouped by category, press the PRG button for at least 1 second and to modify the parameter press DOWN+ START + UP.

Category	Parameters	Message	Icon
Probe parameters	/	‘pro’	
Control parameters	r	‘Ctl’	
Compressor parameters	c	‘CMP’	
Defrost parameters	d	‘dEF’	
Alarm parameters	A	‘ALM’	
Fan parameters	F	‘FAn’	
Configure parameters	H configuration	‘CnF’	
HACCP parameters	H HACCP	‘HcP’	
RTC parameters	rtc	‘rtc’	

6.7 Alarms with manual reset

The alarms with manual reset can be reset by pressing the PRG and UP for more than 3 s.

6.8 HACCP function

ir33+ is compliant with the HACCP standards in force since it allows the monitoring of the temperature of the stored food.

“HA” alarm = exceeded maximum threshold: up to three HA events are saved (HA, HA1, HA2) respectively from the more recent (HA) to the oldest (HA2) and a HAn signal that displays the number of occurred HA events.

“HF” alarm = power failure lasting over a minute and exceeded AH maximum threshold: up to three HF events are saved (HF, HF1, HF2) respectively from the more recent (HF) to the oldest (HF2) and a HFn signal that displays the number of occurred HF events. HA/HF alarm setting: AH parameter (high temp. threshold); Ad and Htd (Ad+Htd = HACCP alarm activation delay).

Display of the details: access to HA or HF parameters pressing the START button and use UP or DOWN buttons to glance over. HACCP alarm erasing: press the DOWN and SET buttons for more than 5 seconds, the message ‘res’ indicates that the alarm have been deleted. To cancel the saved alarms press the DOWN+ START + UP buttons for more than 5 seconds.

6.9 Procedure for setting the default parameter values

To set the default parameter values on the controller, proceed as follows:

- If “Hdn” = 0:

1: switch the instrument off;

2: switch the instrument back on, holding the PRG button until the message “Std” is shown on the display.

Note: the default values are only set for the visible parameters (C and F). For further details see table “Summary of operating parameters”.

- If “Hdn” < > 0:

1: switch the instrument off;

2: switch the instrument back on, holding the PRG button until the value bn0 is shown on the display;

3: select the set of default parameters, between 0 and “Hdn”, using the DOWN and UP buttons;

4: press the START button until the message “Std” is shown on the display.

7. MAINTENANCE

7.1 PERIODIC CLEANING

For hygienic reasons and improved performance clean at least once a month the internal basin. Especially the hole for water out going, need keep clean always, First perform a manual defrosting cycle (par. 6.3),

When complete, switch off the power supply and clean the inside following the instructions given in par. 4.2 (initial cleaning).

7.2 CLEANING OF CONDENSER

For improved performance clean the condenser at least once a week.

Before beginning turn off the equipment, and disconnect the plug.

Close and protect the unit.

- Unscrew, rotate and remove protective grill
- Remove the dust deposited on the front surface of the condenser using a brush and a vacuum cleaner and restore previous conditions.

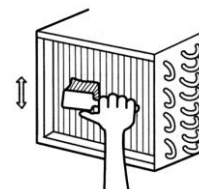

7.3 PERIOD OF INACTIVITY OF CABINET

During periods of inactivity, remove the products from the cabinet and then follow these directions:

- Remove the plug out from the outlet and carefully clean the unit as per periodic cleaning
- Cover the cabinet with a cloth that allows air circulation in the interior.

8. TROUBLE SHOOTING AND REMEDIES

Often, the malfunction of a unit is due to simple causes which can easily be eliminated without contacting a technician. Therefore execute the following controls

8.1 If the cabinet does not operate, make sure that:

- The plug has been correctly inserted into the socket.
- The supply cord is not damaged.

8.2 If the required temperature is not achieved, make sure that;

- The command switch is turned on.
- The electronic control panel is correctly regulated (see 6.1.3, 6.1.4).
- The cabinet is neither in the defrosting phase nor in the post-defrosting phase.
- The evaporator is not covered with frost (see 6.3).
- The condenser is not blocked with dust.
- The cabinet is not located near heat sources or its condensing unit has uninterrupted air flow.
- The stored foods or other objects do not inhibit proper closing of the unit.
- The cabinet is not working in anomalous conditions (overloaded, loaded with hot food, or loaded in a way that prevents proper air circulation).

8.3 If the cabinet leaks water, make that:

- The collecting container or the device for condensing water elimination are not damaged.
- The discharge outlets are not blocked or obstructed.
- The cabinet has been properly leveled.

8.4 If the cabinet is unacceptably noisy, make sure that:

- The frame does not have loose screws or bolts.
- The cabinet has been laid in a stable position and correctly leveled.

If, after all these controls, the malfunctioning continues, it is advisable to contact technical assistance. Be prepared to supply the following information:

- The model trade name and the serial number (both can be found on the technical data plate).
- The alarm codes appearing on the display of the control panel.

8.5 IMPROBABLE RISKS

In case of fire unplug the cabinet, if possible, and use a powder fire extinguisher.

9. SUBSTITUTION OF SPARES

Before commencing any service or maintenance work, isolate the cabinet from the electrical supply. Always fit original spares which may be obtained from an authorized concessionaire or stockist.

10. DISMANTLING

The scrapping of the cabinet requires to be undertaken by specialized company, licensed by the local

authorities, and observing local statutes. Polyurethane foaming material, not fire-resistant, when deal with the material, should be according with local law and statute.

- The cabinet consists of:
- Structure in steel plate,
- Electrical components and cables,
- Electrical compressor.
- Plastic materials,
- Refrigerant fluid which must not be discharged into the atmosphere.

ALL THE RESPONSIBILITY FOR THE FAILURE TO RESPECT THE EXISTING LOCAL STATUTES ARE THE RESPONSIBILITY OF THE OWNER.

Meaning of crossed –out wheeled dustbin:

Do not dispose of electrical appliances as unsorted municipal waste, use separate collection facilities. Contact you local government for information regarding the collection systems available. If electrical appliances are disposed of in landfills or dumps, hazardous substances can leak into the groundwater and get into the food chain, damaging your health and well

-being. When replacing old appliances with new ones, the retailer is legally obligated to take back your old appliance for disposals at least free of charge

Circuit diagram

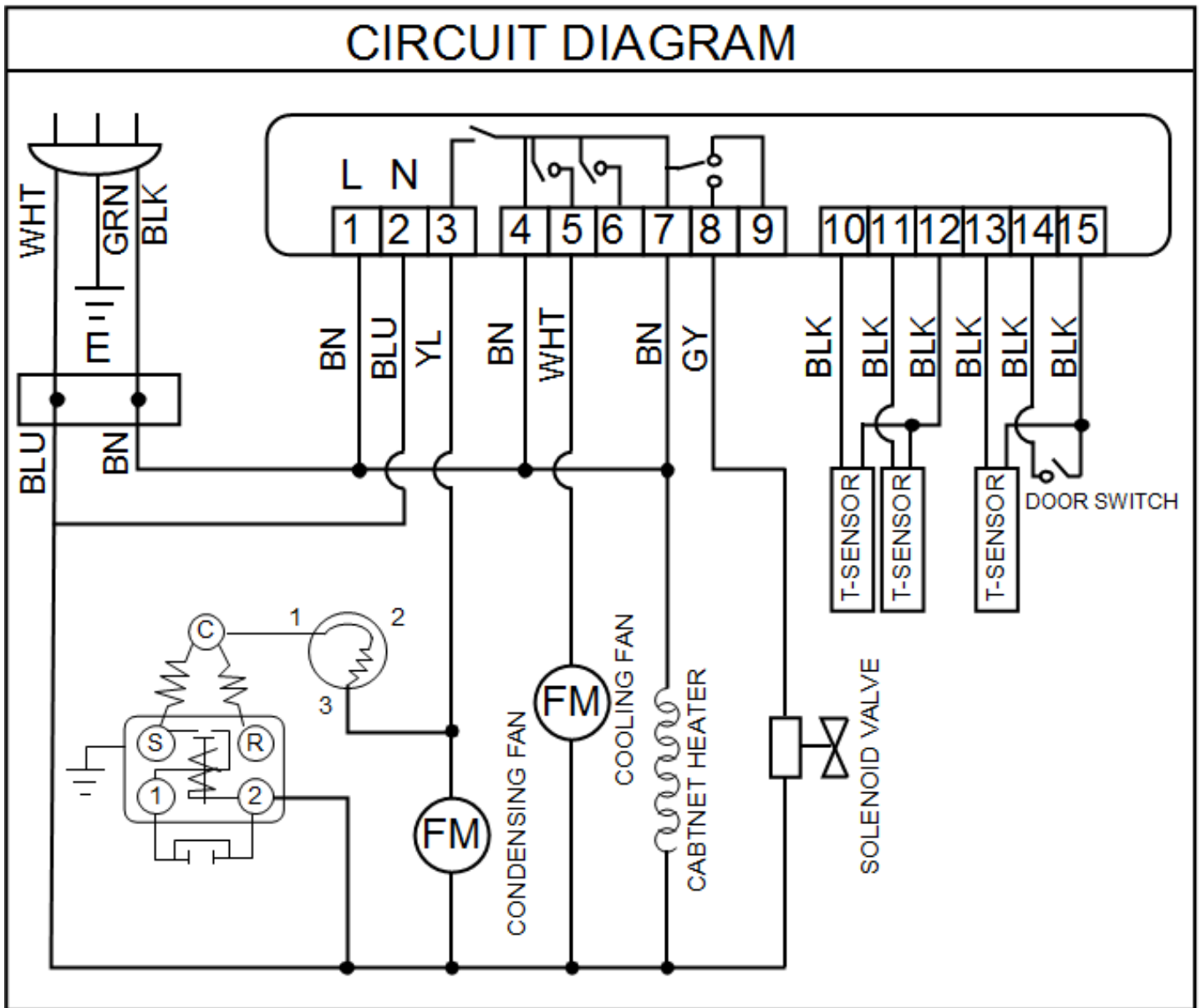

Technical Parameters

Model	EBF-03	EBF-05
Fast cooling performance per cycle/kg	10Kg(+90°C/+3°C) in 90 Min	25Kg(+90°C/+3°C) in 90 Min
Fast freezing performance per cycle/kg	5Kg(+90°C/-18°C) in 240 Min	15Kg(+90°C/-18°C) in 240 Min
Rated voltage	220-240V,50Hz	220-240V,50Hz
Rated power(W)	1100	1300
Current(A)	6	6.5
Auxiliary heater	13	13
Safety climate class	4	4
Volume(L)	-	-
Refrigerant	R290	R290
Amount(g)	150	150
Dimension D×W×H(mm)	755×832×581	750×815×870
Inner fitting	3 trays GN1/1 - 3 trays EN 600×400	5 trays GN1/1 - 5 trays EN 600×400
Condensation	air	air

OFFICIAL APPROVAL AND RULES

Our products full fill the present E.U. rules, including the CE mark of the European official approval Machinery Directive (MD) 2006/42/EC
Electromagnetic Compatibility (EMC) Directive 2014/30/EU

EN 60335-1

EN 60335-2-89

EN 62233

EN 55014-1

EN 55014-2

EN 61000-3-2











EN 61000-3-3

Serial № C003-106-076



Summary of operating parameters

Signals on the display

Icon	Function	Startup	Normal operation		
			ON	OFF	Blinking
	Compressor		compressor ON	compressor OFF	compressor required
	Fan		fan ON	fan OFF	fan required
	Defrost		defrost in progress	defrost no required	defrost required
	AUX		auxiliary output AUX active	auxiliary output AUX not active	anti-sweat heater function active
	Alarm		delayed external alarm (before the expiry of the time 'A7')	no alarm present	alarms and malfunctions
	Clock	ON if RTC present	at least one timed defrost has been set	no timed defrost is present	clock alarm
	Light		auxiliary output LIGHT active	auxiliary output LIGHT not active	anti-sweat heater function active
	Service			no malfunctions	malfunction (es. EEPROM error or probe fault)
	HACCP		function not enabled	function enabled (HA and/or HF)	HACCP alarm enabled
	Blast chilling cycle in progress		Blast chilling cycle in progress	Conservation in progress	

CORRECT DISPOSAL OF THIS PRODUCT



This marking indicates that this product should not be disposed with other household wastes throughout the EU. To prevent possible harm to the environment or human health from uncontrolled waste disposal, recycle it responsibly to promote the sustainable reuse of material resources. To return your used device, please use the return and collection systems or contact the retailer where the product was purchased. They can take this product for environmental safe recycling.

